

Hy-Lok T Series

Trunnion Ball Valves for General

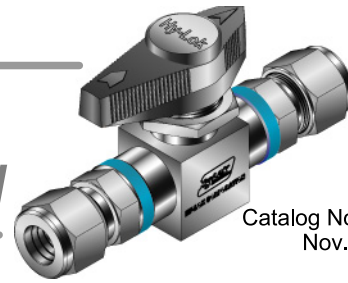

Catalog No. H-100TBV
Nov. 2013

Panel mounting nut

- allow ease installation (standard)

Blowout-proof stem

- bottom-loaded
- provides enhanced safety.

Variety of end connections

- including Hy-Lok tube fittings, male / female ISO, male / female NPT

Rugged Body

- is machined from barstock
- is available in 2-way and 3-way

Handle with arrow

- indicates flow direction.
- low torque and quick operation
- available in black (standard) and colored nylon handle (on request)

Stem bearing

- is PEEK standard

Blowout-proof trunnion ball

- PTFE coated standard

Spring - loaded seats

- ensure positive sealing in pressure and temp. cycling.

Features

- **Pressure rating** up to 10000psig(689 bar) at 100°F (37°C)
- **End connections** available Hy-Lok tube fittings and female NPT
- **Compact, maximum flow design**
- **Low operating torque**
- **2-way "Shut-Off" and 3-way "Switching" models**
- **Body materials** available in 316 stainless steel and Alloy 400
- **100% factory tested**



The flow direction is indicated on top of the stem for reference purposes when the handle is removed for panel mounting

Technical Data

Pressure-Temperature Rating

Seat Material	Temperature Rating	Pressure Rating at 100°F(37°C)	
		Stainless Steel	Alloy 400
T Series			
PCTFE	0°F to 250°F (-17°C to 121°C)	6000 psig (413 bar)	5000 psig (344 bar)
PEEK	0°F to 450°F (-17°C to 232°C)	1500 psig (103 bar)	
PTFE			
TH Series			
PEEK	0°F to 450°F (-17°C to 232°C)	10000 psig (689 bar) depending on end Connection	-

Testing

- Each valve is tested with nitrogen @1000psig(69 bar) to max. leak rate of 0.1SCCM.
- Hydrostatic shell test is performed at 1.5 times the working pressure as an option.
- Other tests are available upon request.

T Series

Body Material	SS316			Alloy 400		
	Seat Material PCTFE	PEEK	PTFE	PCTFE	PEEK	PTFE
Temperature, °F(°C)						
Working Pressure, psig(bar)						
0(-17) to 100(37)	6000(413)	6000(413)	1500(103)	5000(344)	5000(344)	1500(103)
150(65)	3000(206)	5800(399)	1125(77.5)	3000(206)	4690(323)	1125(77.5)
200(93)	2000(137)	5000(344)	750(51.6)	2000(137)	4390(302)	750(51.6)
250(121)	1000(68.9)	4100(282)	625(43.0)	1000(68.9)	4100(282)	625(43.0)
300(148)	-	3200(220)	500(34.4)	-	3200(220)	500(34.4)
350(176)	-	2300(158)	375(25.8)	-	2300(158)	375(25.8)
400(204)	-	1400(96.4)	250(17.2)	-	1400(96.4)	250(17.2)
450(232)	-	500(34.4)	125(8.6)	-	500(34.4)	125(8.6)

TH Series

Body Material	SS316					
	End Connection Female 1/8", 1/4" Hy-Lok 1/4", 6mm	Hy-Lok 8mm	Hy-Lok 12mm	Hy-Lok 3/8"	Hy-Lok 1/2"	Hy-Lok 10mm
Temperature, °F(°C)						
Working Pressure, psig(bar)						
0(-17) to 100(37)	10000(689)	7500(516)	6600(454)	6500(447)	6700(461)	6000(413)
150(65)	7500(516)	7500(516)	6600(454)	6500(447)	6700(461)	5900(406)
200(93)	5000(344)	5000(344)	5000(344)	5000(344)	5000(344)	5000(344)
250(121)	4100(282)	4100(282)	4100(282)	4100(282)	4100(282)	4100(282)
300(148)	3200(220)	3200(220)	3200(220)	3200(220)	3200(220)	3200(220)
350(176)	2300(158)	2300(158)	2300(158)	2300(158)	2300(158)	2300(158)
400(204)	1400(96.4)	1400(96.4)	1400(96.4)	1400(96.4)	1400(96.4)	1400(96.4)
450(232)	500(34.4)	500(34.4)	500(34.4)	500(34.4)	500(34.4)	500(34.4)



HY-LOK CORPORATION

T Series (up to 6000 psig)

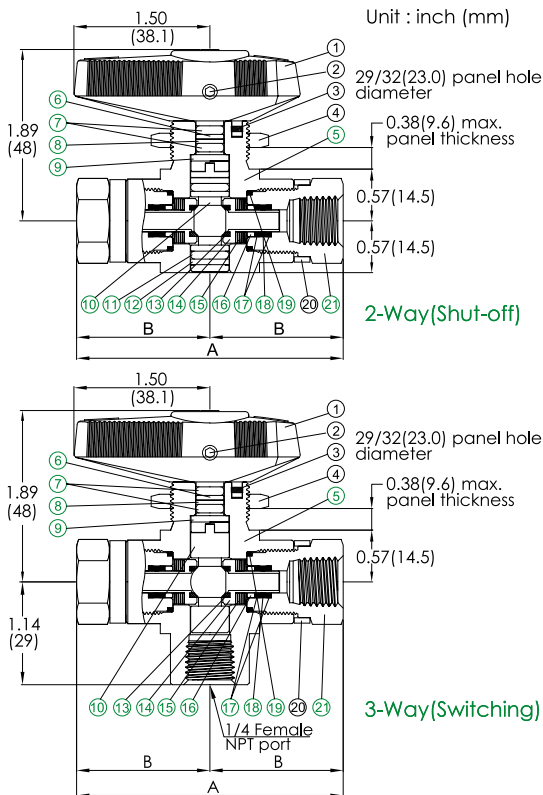

Material of Construction

No.	Component	Valve Body Material			
		Stainless Steel		Alloy 400	
		2-Way	3-Way	2-Way	3-Way
Material Grade / ASTM Specification					
1	Handle	Nylon 6/6 with Brass Insert			
2	Set Screw	Stainless Steel			
3	Stop Pin <small>(2-Way; 2, 3-Way: 1)</small>	Stainless Steel			
4	Panel Nut	316 Stainless Steel			
5	Body	TP316 / A479 or A182		N04400 / B164	
6	Stem	TP316 / A479		N04400 / B164	
7	Stem O-Ring	FKM			
8	Stem Backup Ring	PTFE			
9	Stem Bearing	PEEK			
10	Trunnion Ball	TP316 / A479		N04400 / B164	
11	Ball O-Ring	FKM	-	FKM	-
12	Ball Back-up Ring	PTFE	-	PTFE	-
13	Seat	PCTFE / PTFE / PEEK			
14	Seat Carrier	TP316 / A479		N04400 / B164	
15	Seat Spring <small>(10 with PTFE; 12 with all others)</small>	Alloy X-750			
16	Seat Carrier Guide	TP316 / A479		N04400 / B164	
17	Seat Carrier Back-up Ring	PTFE			
18	Seat Carrier O-Rings	FKM			
19	End Packing	PTFE			
20	Identification Ring	Nylon			
21	End Connection	TP316 / A479		N04400 / B164	

Wetted parts numbered in green.
Molybdenum disulfide and fluoro-carbon based lubricant is used.

Table of Dimensions

Basic Part Number		Orifice in. (mm)	Flow Coefficient (Cv)	End Connections		Dimensions, in. (mm)	
				Inlet & Outlet		A	B
2-way T	F - 2N	0.188 (4.8)	1.2	1/8 Female NPT		2.94 (74.7)	1.47 (37.35)
	F - 4N			1/4 Female NPT			
	H - 4T			1/4 Hy-Lok		4.14 (105.2)	2.07 (52.6)
	H - 6T			3/8 Hy-Lok		4.39 (111.2)	2.19 (55.6)
	H - 8T			1/2 Hy-Lok		4.60 (116.8)	2.30 (58.4)
	H - 6M			6mm Hy-Lok		4.14 (105.2)	2.07 (52.6)
	H - 8M			8mm Hy-Lok		4.14 (105.2)	2.07 (52.6)
	H - 10M			10mm Hy-Lok		4.40 (111.8)	2.20 (55.9)
	H - 12M			12mm Hy-Lok		4.60 (116.8)	2.30 (58.4)
3-way T3	F - 4N2N	0.188 (4.8)	0.75	1/8 Female NPT	2.94 (74.7)	1.47 (37.35)	
	F - 4N			1/4 Female NPT			
	FH - 4N4T			1/4 Hy-Lok		4.14 (105.2)	2.07 (52.6)
	FH - 4N6T			3/8 Hy-Lok		4.39 (111.2)	2.19 (55.6)
	FH - 4N8T			1/2 Hy-Lok		4.60 (116.8)	2.30 (58.4)
	FH - 4N6M			6mm Hy-Lok		4.14 (105.2)	2.07 (52.6)
	FH - 4N8M			8mm Hy-Lok		4.14 (105.2)	2.07 (52.6)
	FH - 4N10M			10mm Hy-Lok		4.40 (111.8)	2.20 (55.9)
	FH - 4N12M			12mm Hy-Lok		4.60 (116.8)	2.30 (58.4)

All dimensions in inches and millimeters are for reference only, subject to change. Dimensions shown with Hy-Lok nuts in finger-tight position, where applicable.

Flow Rate @ 70 °F (21 °C)

Pressure Drop to Atmosphere (Δp) in psi (bar)		2-Way Flow Coefficient (Cv)						3-Way Flow Coefficient (Cv)
		1.0	1.2	1.3	1.4	1.5	1.6	0.75
Air SCFM (std L/min)	10 (0.68)	11.0 (311)	14.0 (396)	15.0 (424)	16.0 (453)	17.0 (481)	18.0 (509)	8.0 (226)
	50 (3.4)	30.0 (849)	36.0 (1019)	39.0 (1104)	42.0 (1189)	45.0 (1274)	48.0 (1359)	23.0 (651)
	100 (6.8)	53.0 (1500)	64.0 (1812)	69.0 (1953)	74.0 (2095)	80.0 (2265)	85.0 (2406)	40.0 (1132)
Water U.S. GPM (std L/min)	10 (0.68)	3.2 (12.1)	3.8 (14.3)	4.1 (15.5)	4.4 (17.8)	4.7 (17.8)	5.1 (19.3)	2.4 (9.0)
	50 (3.4)	7.1 (26.8)	8.5 (32.1)	9.2 (34.8)	9.9 (37.4)	10.6 (40.1)	11.3 (42.7)	5.3 (20.0)
	100 (6.8)	10.0 (37.8)	12.0 (45.4)	13.0 (49.2)	14.0 (53.0)	15.0 (56.7)	16.0 (60.5)	7.5 (28.3)

TH Series (up to 10000 psig)

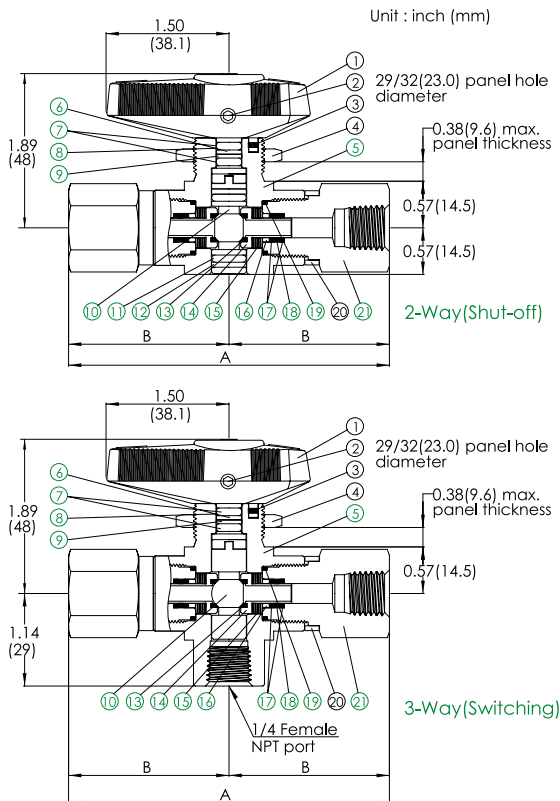

Material of Construction

No.	Component	Valve Body Material	
		Stainless Steel	
		2-Way	3-Way
Material Grade / ASTM Specification			
1	Handle	Nylon 6/6 with Brass Insert	
2	Set Screw	Stainless Steel	
3	Stop Pin(2-Way: 2, 3-Way: 1)	Stainless Steel	
4	Panel Nut	316 Stainless Steel	
5	Body	TP316 / A479 or A182	
6	Stem	TP316 / A479	
7	Stem O-Ring	FKM	
8	Stem Backup Ring	PTFE	
9	Stem Bearing	PEEK	
10	Trunnion Ball	TP316 / A479	
11	Ball O-Ring	FKM	-
12	Ball Backup Ring	PTFE	-
13	Seat	PEEK	
14	Seat Carrier	TP316 / A479	
15	Seat Spring	Alloy X-750	
16	Seat Carrier Guide	TP316 / A479	
17	Seat Carrier Backup Ring	PTFE	
18	Seat Carrier O-Rings	FKM	
19	End Packing	PTFE	
20	Identification Ring	Nylon	
21	End Connection	TP316 / A479	

Wetted parts numbered in green.
Molybdenum disulfide and fluoro-carbon based lubricant is used.

Table of Dimensions

Basic Part Number		Orifice in. (mm)	Flow Coefficient (Cv)	End Connections		Dimensions, in. (mm)	
				Inlet & Outlet		A	B
2-way	F - 2N	0.188 (4.8)	1.2	1/8 Female NPT		2.94 (74.7)	1.47 (37.35)
	F - 4N			1/4 Female NPT		3.93 (99.8)	1.97 (49.9)
	H - 4T			1/4 Hy-Lok		4.14 (105.2)	2.07 (52.6)
	H - 6T			3/8 Hy-Lok		4.39 (111.2)	2.19 (55.6)
	H - 8T			1/2 Hy-Lok		4.60 (116.8)	2.30 (58.4)
	H - 6M			6mm Hy-Lok		4.14 (105.2)	2.07 (52.6)
	H - 8M			8mm Hy-Lok		4.14 (105.2)	2.07 (52.6)
	H - 10M			10mm Hy-Lok		4.40 (111.8)	2.20 (55.9)
	H - 12M			12mm Hy-Lok		4.60 (116.8)	2.30 (58.4)
3-way	F - 4N2N	0.188 (4.8)	0.75	1/4 Female NPT (bottom port)	1/8 Female NPT	2.94 (74.7)	1.47 (37.35)
	F - 4N				1/4 Female NPT	3.93 (99.8)	1.97 (49.9)
	FH - 4N4T				1/4 Hy-Lok	4.14 (105.2)	2.07 (52.6)
	FH - 4N6T				3/8 Hy-Lok	4.39 (111.2)	2.19 (55.6)
	FH - 4N8T				1/2 Hy-Lok	4.60 (116.8)	2.30 (58.4)
	FH - 4N6M				6mm Hy-Lok	4.14 (105.2)	2.07 (52.6)
	FH - 4N8M				8mm Hy-Lok	4.14 (105.2)	2.07 (52.6)
	FH - 4N10M				10mm Hy-Lok	4.40 (111.8)	2.20 (55.9)
	FH - 4N12M				12mm Hy-Lok	4.60 (116.8)	2.30 (58.4)

All dimensions in inches and millimeters are for reference only, subject to change. Dimensions shown with Hy-Lok nuts in finger-tight position, where applicable.

Flow Rate @ 70 °F (21 °C)

Pressure Drop to Atmosphere (Δp) in psi (bar)		2-Way Flow Coefficient (Cv)						3-Way Flow Coefficient (Cv)
		1.0	1.2	1.3	1.4	1.5	1.6	0.75
Air SCFM (std L/min)	150 (10.3)	76 (2152)	92 (2805)	99 (2803)	107 (3029)	115 (3256)	122 (3454)	57 (1614)
	600 (41.3)	285 (8070)	340 (9627)	371 (10505)	399 (11298)	428 (12119)	456 (12912)	210 (5946)
Water U.S. GPM (std L/min)	1000 (68.9)	470 (13308)	570 (16140)	610 (17272)	660 (18688)	700 (19821)	750 (21321)	350 (9912)
	150 (10.3)	12 (45.4)	15 (56.7)	16 (60.5)	17 (64.3)	18 (68.1)	19.6 (74.1)	9.2 (34.8)
600 (41.3)	25 (94)	29 (109)	32 (121)	34 (128)	37 (140)	39 (147)	41 (154)	18 (69.1)
	1000 (68.9)	38 (143)	38 (143)	41 (155)	44 (166)	47 (178)	50 (189)	24 (90.8)

Option

T Series Vent Option

T series 2-way valves are available of using in a downstream or an upstream vent on customer's request. A path of the vent in the ball does not intersect the main flow passage so that it is ensuring no leakage of system media from the vent port. In case "open" position of the valve, flow is straight through. The pressure rating with a ball vent is reduced to 500 psig (34.4 bar).

Downstream (DV) Vent

In case close position of a downstream-vented valve, full shutoff occurs at the upstream seat. Downstream line media passes through vent hole penetrated through the bottom of the trunnion and vents to atmosphere.

Upstream (UV) Vent

In case close position of the upstream-vented valve, full shutoff occurs at the downstream seat. Upstream line media passes through vent hole penetrated through the bottom of the trunnion and vents to atmosphere.

Accessories

Spare Kits

Valve Series	Basic Ordering No.	Kit Contains
T Series 2-Way Kit	KIT-T-SET	Instructions, trunnion ball subassemblies (ball(1), O-ring(2) and back-up ring(2)), stem subassemblies (stem(1), stem bearing(1), O-ring(2) and back-up ring(1)), seat subassemblies (seat(2) and seat carriers(2)), seat spring (10 with PTFE seat, 12 with all others), seat carrier guide(2), seat carrier O-ring(2), seat carrier back-up ring(4), end screw seats(2)
T Series 3-Way Kit	KIT-T3-SET	Instruction, trunnion ball(1), stem subassemblies (stem(1), bearing(1), O-ring(2) and back-up ring(1)), seat subassemblies (seat(2) and seat carriers(2)), seat spring (10 with PTFE seat, 12 with all others) seat carrier guide(2), seat carrier O-ring(2), seat carrier back-up ring(4), end screw seats(2)

Spare kits contain components of the same material as new components. See Material of Construction, page 2 and 3. For a complete ordering number, add the desired seat material designator and body material designator as a suffix to the basic spare kit ordering number. Example : KIT-T-SET-P-MONE

Valve Series	Basic Ordering No.	Kit Contains
TH Series 2-Way Kit	KIT-TH-SET	Instructions, trunnion ball subassemblies (ball(1), O-ring(2) and back-up ring(2)), stem subassemblies (stem(1), stem bearing(1), O-ring(2) and back-up ring(1)), seat subassemblies (seat(2) and seat carriers(2)), seat spring(12), seat carrier guide(2), seat carrier O-ring(2), seat carrier back-up ring(4), end screw seats(2)
TH Series 3-Way Kit	KIT-TH3-SET	Instruction, trunnion ball(1), stem subassemblies (stem(1), bearing(1), O-ring(2) and back-up ring(1)), seat subassemblies (seat(2) and seat carriers(2)), seat spring (12), seat carrier guide(2), seat carrier O-ring(2), seat carrier back-up ring(4), end screw seats(2)

Body components and seat material of THB Series are made of only stainless steel and PEEK respectively.

Ordering Information

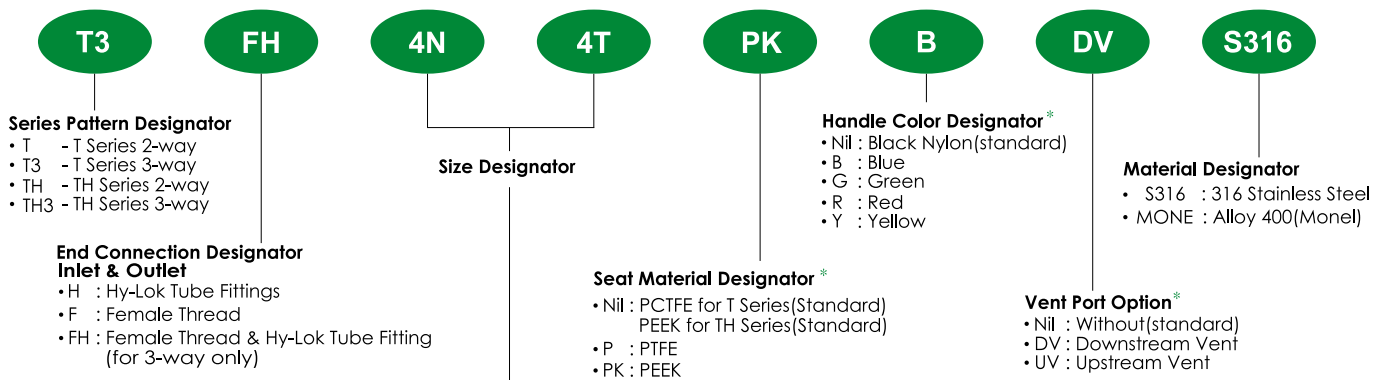

CAUTION

T Series Ball Valve shall not be used for CNG System.

SAFETY in VALVE SELECTION

Proper installation, material compatibility, operation and maintenance of these valves are the responsibility of the user. The total system design must be taken into consideration to ensure optimal performance and safety.